

Installation Instructions



Important Preinstallation Note: These instructions are only for **inaccessible ceilings** (gypsum board or selected concealed). For other ceiling conditions, consult factory. Whip flex, screws and anchors supplied by others. Handle fixture by sheet metal sides only.

LIGHT FIELDS™ LED LFS
Surface-Mounted LED Fixture
Inaccessible Ceilings Only

DO NOT REMOVE THE LED GEARTRAYS. THIS WILL VOID THE WARRANTY. Call Zumtobel at 1-800-448-4131 for questions.

DANGER



RISK OF FIRE AND ELECTRICAL SHOCK

Contact, improper installation, or improper servicing MAY RESULT IN DEATH OR SERIOUS INJURY!

Fixture must be installed by a qualified electrician only. Fixture is intended for installation in accordance with the National Electrical Code, local and federal code specifications. Disconnect power at electrical panel before servicing. Retain these instructions for maintenance reference.

1 Unpack fixture(s). Fixture is shipped fully assembled as a complete unit.

2 Remove door frame containing lens by holding door frame with one hand, and with the other hand, inserting a finger into the hole on the back of the housing and pulling housing and door frame apart until they detach from each other. Keep door frame aside in safe location.



3 Make electrical connections. Attach power supply from ceiling to 1/2" conduit through 7/8" diameter hole in knockout at feed point. Pull wires through hole and make wiring connections, as per NEC and local codes.



4 Attach housing to ceiling at the provided mounting points using screws (by others).

Distance between mounting points:

Surface:	Suspended:
2x2 – 16" o.c.	2x2 – 18" o.c.
1x4 – 36" o.c. and 6" o.c.	1x4 – 38" o.c. and 6" o.c.

2' X 2' Surface/Suspended

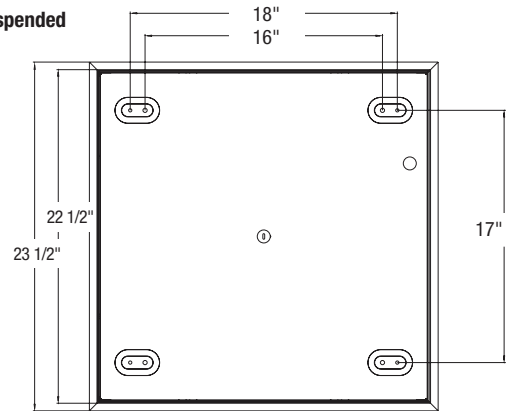

1' X 4' Surface/Suspended

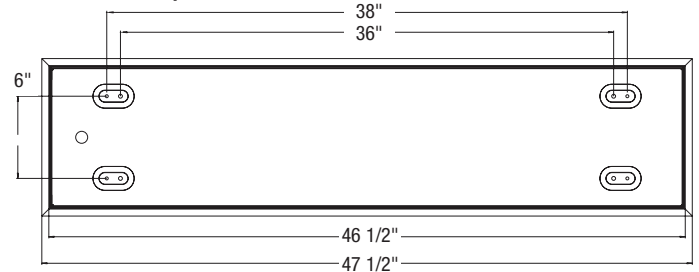

Questions? Problems? Call (800) 448-4131 and we will be happy to assist you. For technical specification sheets or other information about our products, please go to www.zumtobel.us



Installation Instructions



Important Preinstallation Note: These instructions are only for **inaccessible ceilings** (gypsum board or selected concealed). For other ceiling conditions, consult factory. Whip flex, screws and anchors supplied by others. Handle fixture by sheet metal sides only.

**LIGHT FIELDS™ LED LFS
Surface-Mounted LED Fixture
Inaccessible Ceilings Only**

DO NOT REMOVE THE LED GEARTRAYS. THIS WILL VOID THE WARRANTY. Call Zumtobel at 1-800-448-4131 for questions.



DANGER

RISK OF FIRE AND ELECTRICAL SHOCK

Contact, improper installation, or improper servicing MAY RESULT IN DEATH OR SERIOUS INJURY!

Fixture must be installed by a qualified electrician only. Fixture is intended for installation in accordance with the National Electrical Code, local and federal code specifications. Disconnect power at electrical panel before servicing. Retain these instructions for maintenance reference.



5 Suspend door frame from housing by linking safety cables from door frame into the tabs on one side of housing, so the door frame hangs.

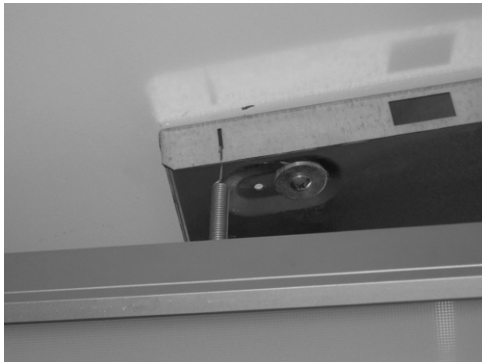

6 Reattach door frame by pushing upwards on all sides onto housing, until it securely clicks into fixture without any gaps.



For Emergency Backup surface mount fixtures, a hole will need to be cut into the mounting location for the EM pack bump out. Use the below dimensions for cutting out the hole in the ceiling. Install the fixture by following the installation instructions above.

For 1x4 Ceiling Mount:

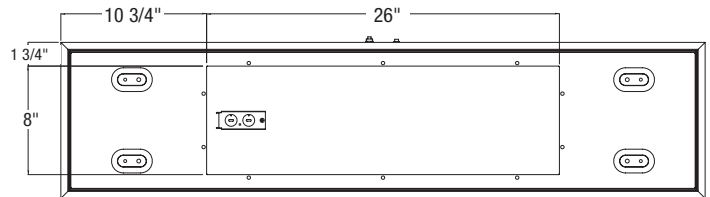

Ceiling Cut-Out for EM Box to be 8 5/8" x 26 5/8"

For 2x2 Ceiling Mount:

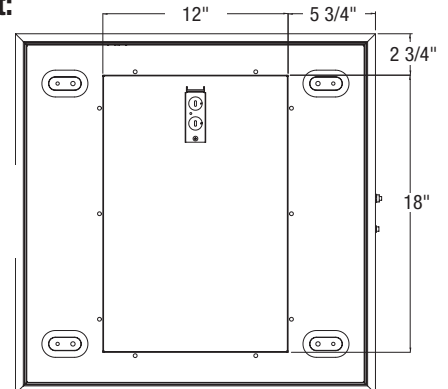

Ceiling Cut-Out for EM Box to be 12 5/8" x 18 5/8"

Maintenance - Turn off power first!

1 Cleaning. Wipe with a soft, lint-free cloth to avoid scratching the acrylic protective layer. Do not use glass cleaner or other solvents.

2 Access to driver. Pull down on lens housing, until the fixture comes loose. Remove safety springs. Remove screws from back of housing to remove from the lens assembly.

3 Replacement of LED boards. Contact Zumtobel at 1 (800) 448-4131.

WHEN REPLACING PCB ASSEMBLIES, PLEASE WEAR AN ESD WRIST STRAP AND CONNECT IT TO THE METAL ENCLOSURE.