

Installation Instructions



Onico Medium and Large Global Trac®

DO NOT REMOVE THE LED ASSEMBLY. THIS WILL VOID THE WARRANTY. Call Zumtobel at 1-800-448-4131 for questions

RISK OF FIRE AND ELECTRICAL SHOCK

Contact, improper installation, or improper servicing MAY RESULT IN DEATH OR SERIOUS INJURY! Fixture must be installed by a qualified electrician only. Fixture is intended for installation in accordance with the National Electrical Code, local and federal code specifications. Disconnect power at electrical panel before servicing. Retain these instructions for maintenance reference.

ADVERTENCIA: Riesgo de incendio o impacto eléctrico.

Conexión, instalación inapropiada o servicio incorrecto PUEDE CAUSAR MUERTE O HERIDAS GRAVES. La luminaria debe ser instalada únicamente por un eléctrico calificado. La luminaria debe instalarse de acuerdo al Norma eléctrica nacional, al igual que especificaciones locales y normas federales. Se debe desconectar la corriente eléctrica antes de realizar la mantención. Conservar estas instrucciones como referencia para futuras mantenciones.

ATTENTION : RISQUE D'INCENDIE ET D'ELECTROCUTION.

Une installation, un entretien ou un contact physique non conforme pourraient mener à un DANGER DE MORT OU DE BLESSURE GRAVE! L'appareil doit être installé uniquement par un électricien professionnel qualifié. L'installation doit respecter le code électrique national de même que les lois locales et fédérales en vigueur. Veuillez fermer l'alimentation électrique au panneau principal avant tout entretien. Conservar ces instructions pour référence et tout entretien futur.

The following installation instructions relate to the options below

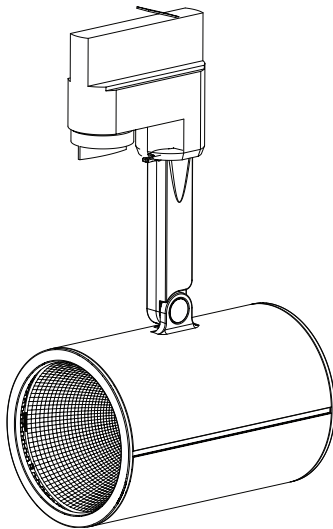

Onico for Global Trac® , Medium

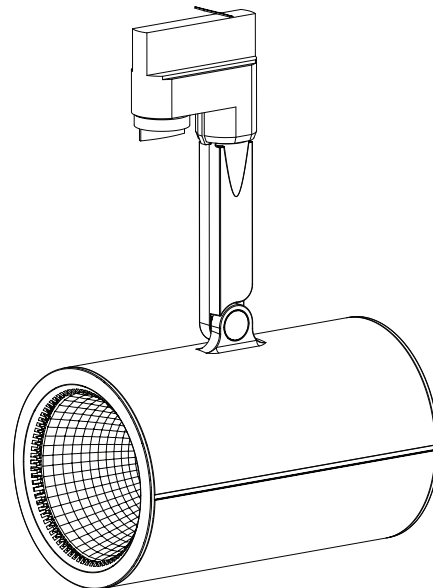

Onico for Global Trac® , Large

Fixture does not include Global Trac® system. This may be ordered separately through Zumtobel

Installation Instructions



Onico Medium and Large Global Trac®

DO NOT REMOVE THE LED ASSEMBLY. THIS WILL VOID THE WARRANTY. Call Zumtobel at 1-800-448-4131 for questions

Global Trac® Installation

Two Circuit

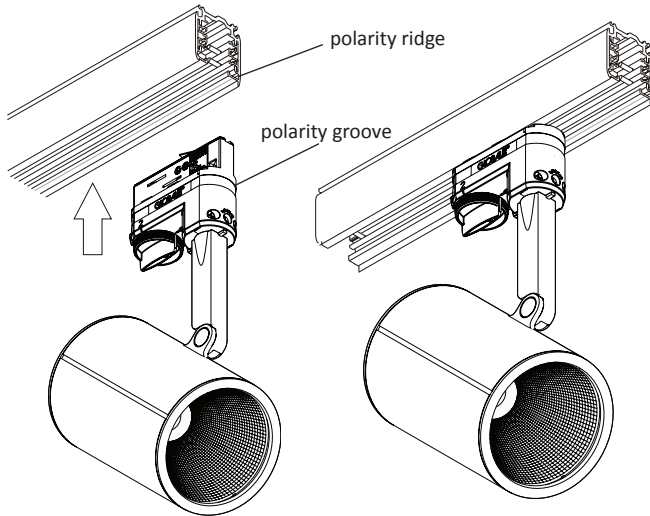

1 Insert fixture into track. The fixture adapter is inserted with the polarity groove towards the polarity ridge on the track. Push the adapter into the track until it snaps into place.

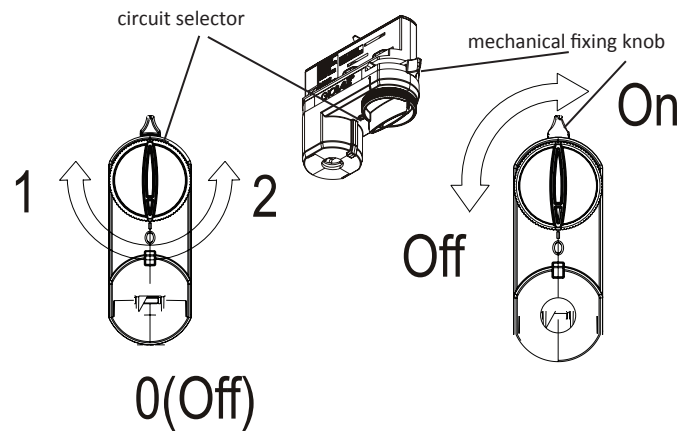

2 Turn the mechanical fixing knob clockwise to secure fixture into place.
3 Select the desired circuit with the circuit selector knob (1-0-2).

Installation Instructions



Onico Medium and Large Global Trac®

DO NOT REMOVE THE LED ASSEMBLY. THIS WILL VOID THE WARRANTY. Call Zumtobel at 1-800-448-4131 for questions

Tilting and Rotation of Fixture

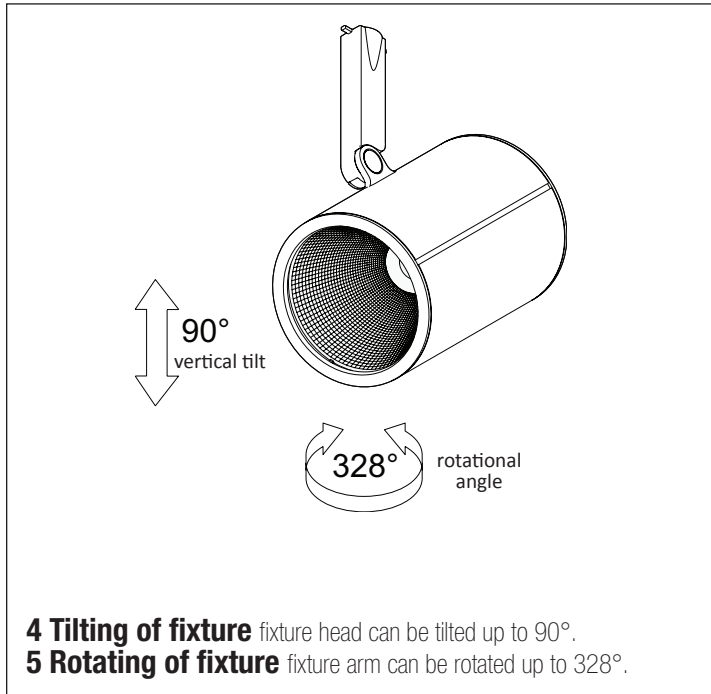

Installation Instructions



Onico Medium and Large Global Trac®

DO NOT REMOVE THE LED ASSEMBLY. THIS WILL VOID THE WARRANTY. Call Zumtobel at 1-800-448-4131 for questions

Reflector Installation

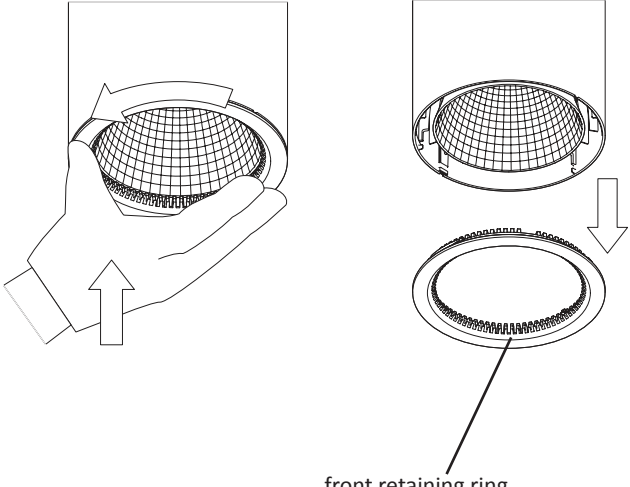
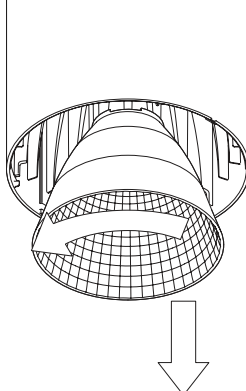
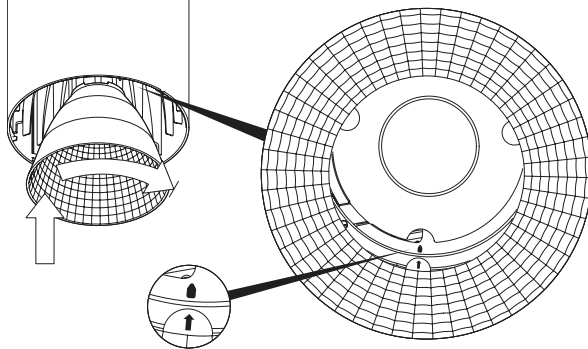
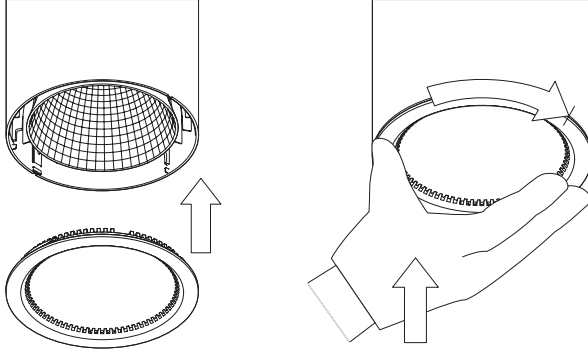
 <p>1 Remove front retaining ring by twisting it counterclockwise and pulling it off of the fixture.</p>	 <p>2 Remove the current reflector by twisting it counterclockwise and pulling it out of the fixture.</p>
 <p>3 Insert the replacement reflector into the fixture, making sure that the arrows line up as shown above. Once the arrows are lined up, twist it clockwise to secure it into place.</p>	 <p>4 Place the front retaining ring back onto the fixture, and twist it clockwise to secure it into place.</p>

Installation Instructions



ONICO Accessories Lenses and Louvres

DO NOT REMOVE THE LED ASSEMBLY. THIS WILL VOID THE WARRANTY. Call Zumtobel at 1-800-448-4131 for questions

Accessory Installation

