



Claris

WHEN REPLACING PCB ASSEMBLIES, PLEASE WEAR AN ESD WRIST STRAP AND CONNECT IT TO ELECTRICAL GROUND

RISK OF FIRE AND ELECTRICAL SHOCK

Contact, improper installation, or improper servicing MAY RESULT IN DEATH OR SERIOUS INJURY! Fixture must be installed by a qualified electrician only. Fixture is intended for installation in accordance with the National Electrical Code, local and federal code specifications. Disconnect power at electrical panel before servicing. Retain these instructions for maintenance reference.

ADVERTENCIA: RIESGO DE INCENDIO O IMPACTO ELÉCTRICO

Conexión, instalación inapropiada o servicio incorrecto PUEDE CAUSAR MUERTE O HERIDAS GRAVES. La luminaria debe ser instalada únicamente por un eléctrico calificado. La luminaria debe instalarse de acuerdo al Norma eléctrica nacional, al igual que especificaciones locales y normas federales. Se debe desconectar la corriente eléctrica antes de realizar la mantención. Conservar estas instrucciones como referencia para futuras mantenciones.

ATTENTION: RISQUE D'INCENDIE ET D'ELECTROCUTION

Une installation, un entretien ou un contact physique non conforme pourraient mener à un DANGER DE MORT OU DE BLESSURE GRAVE! L'appareil doit être installé uniquement par un électricien professionnel qualifié. L'installation doit respecter le code électrique national de même que les lois locales et fédérales en vigueur. Veuillez fermer l'alimentation électrique au panneau principal avant tout entretien. Conservé ces instructions pour référence et tout entretien futur.

NOTE

National or municipal codes must be followed regarding fixture installation and set back of thermal insulating material from luminaire. As a guideline, any insulation material must be held away from the luminaire by minimum of 3". Fixtures are not designed for direct contact with thermal insulation.



i Overview

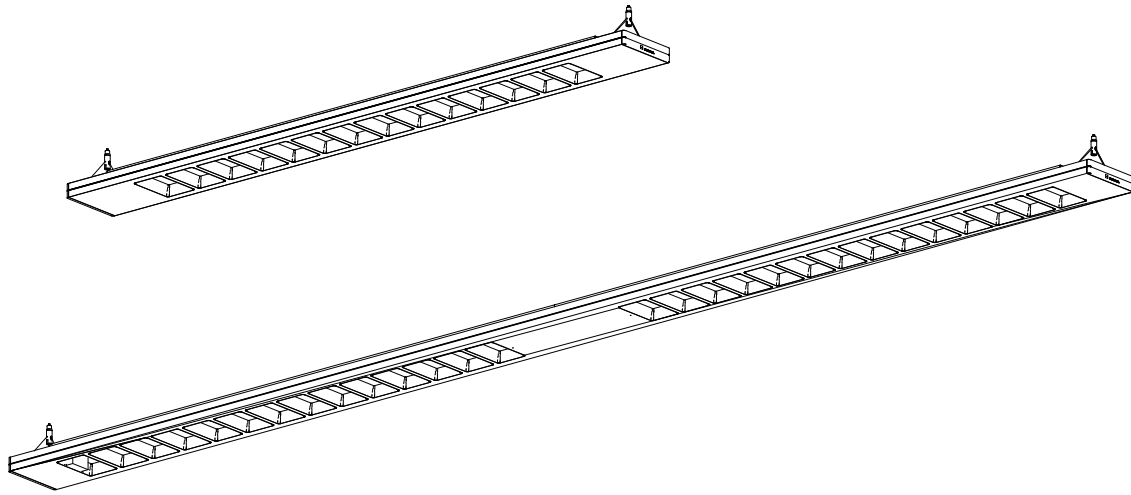

i single luminaire (A)

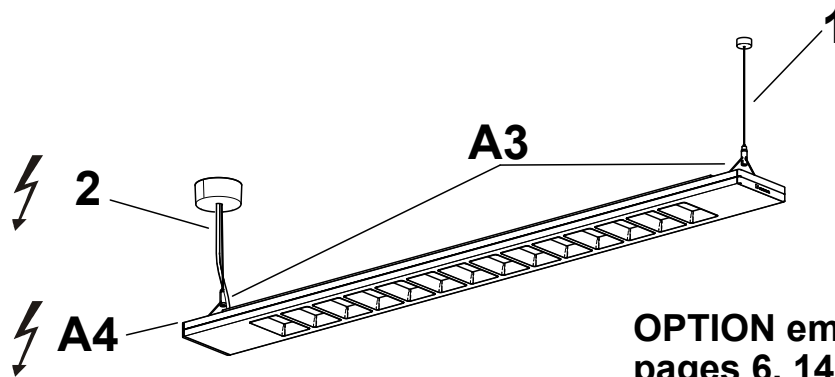

OPTION emergency lighting:
pages 6, 14

i OPTION: continuous row (B)

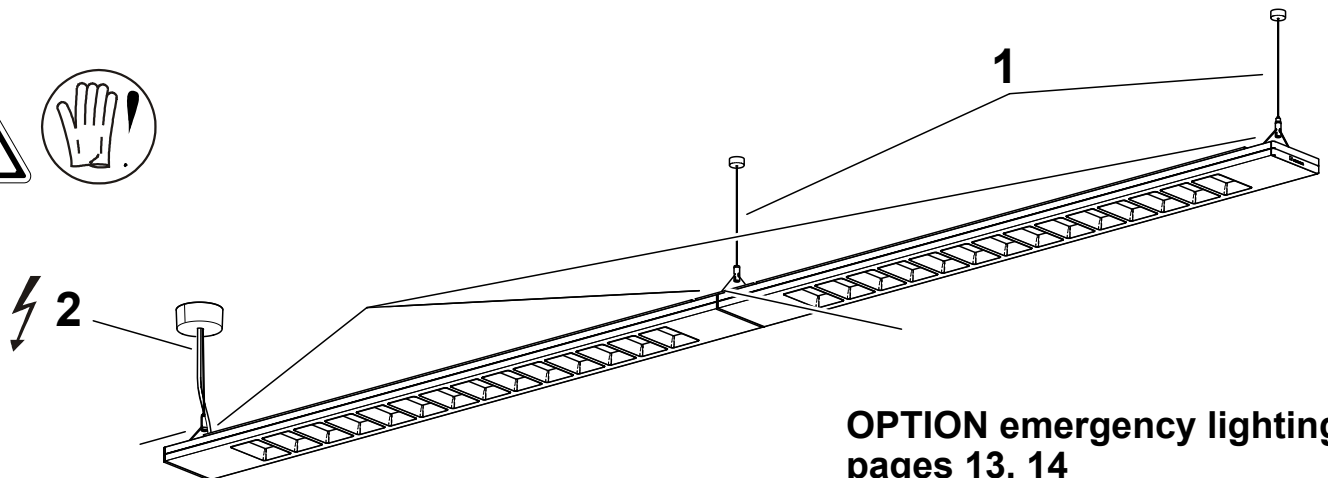

OPTION emergency lighting:
pages 13, 14

i single luminaire

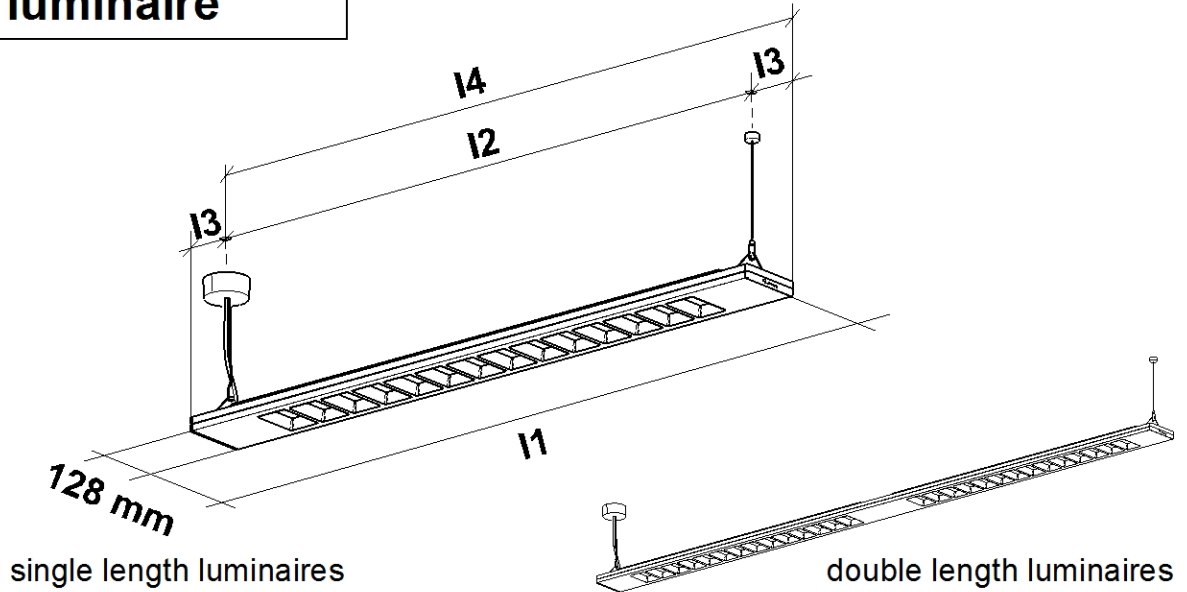

i continuous row

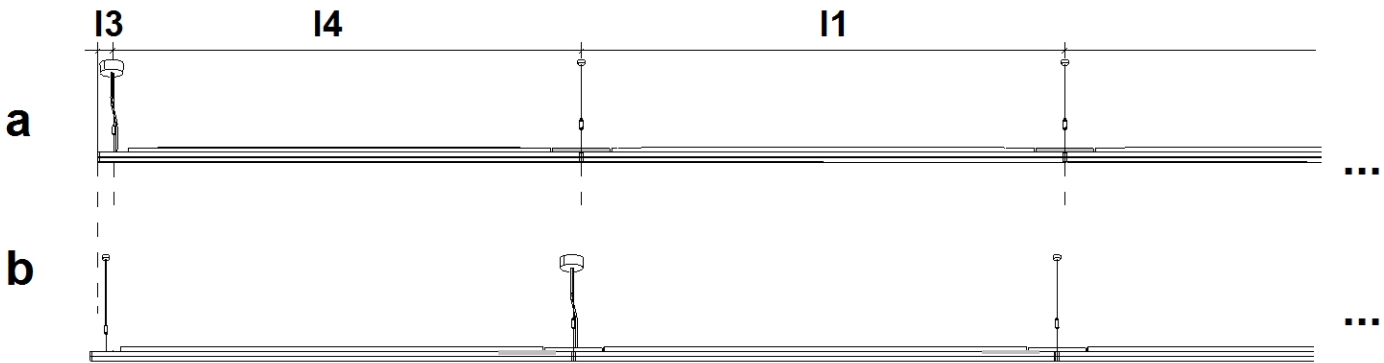
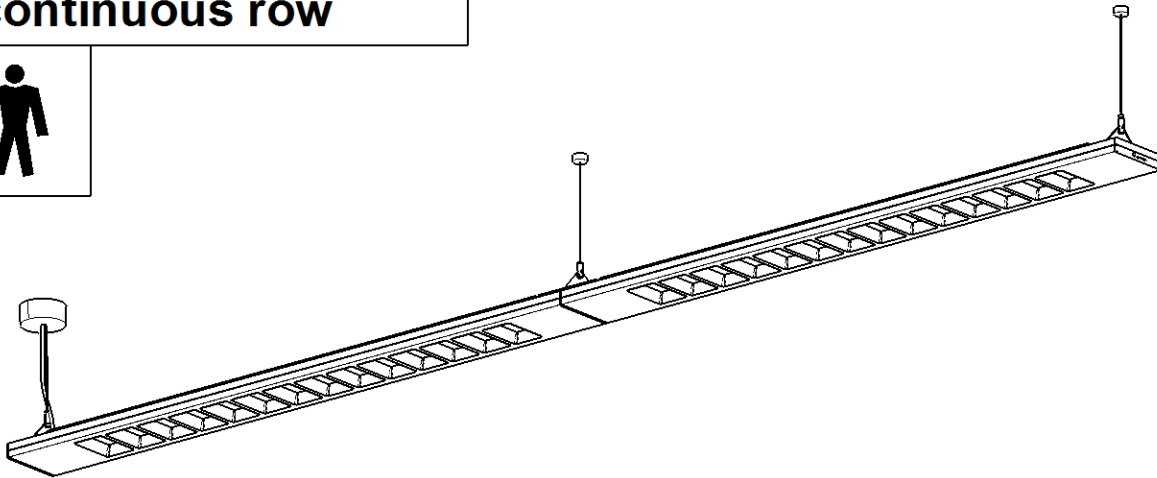

i

(dimensions in mm)	I1	I2	I3	I4	kg
CLEVO ID 1280 *	1280	1195	42,5	1237,5	3,50
CLEVO ID 2480 (E3D) **	2480	2395	42,5	2437,5	7,38

* single length luminaires ** double length luminaires

i OPTION :

single length luminaire

double length luminaire

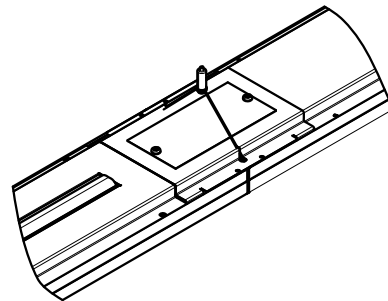
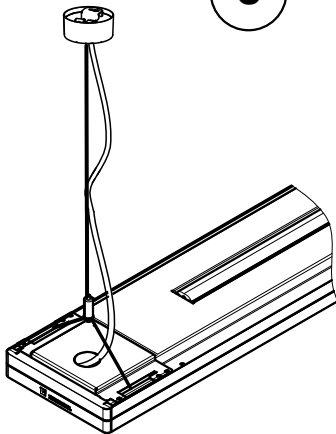
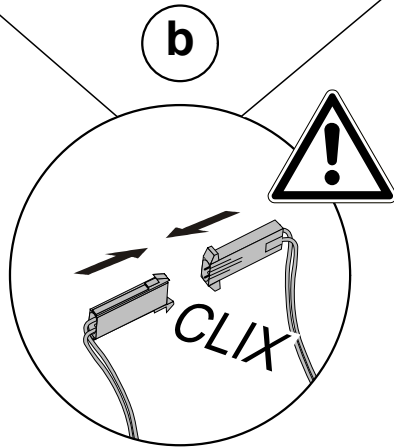
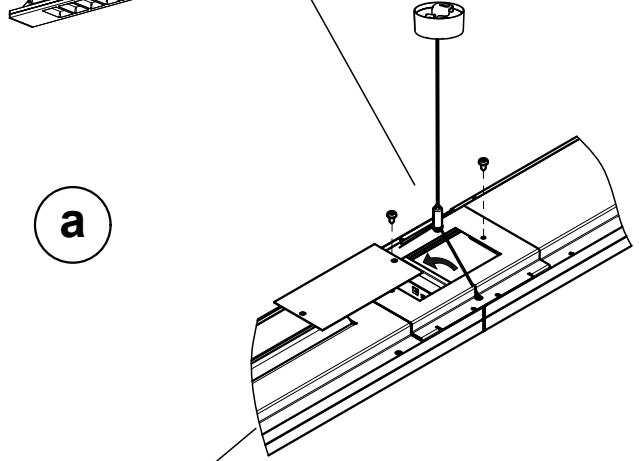
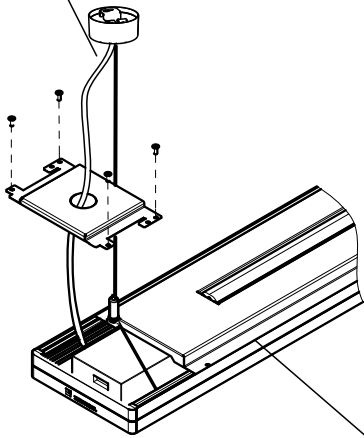

B3 continuous row only

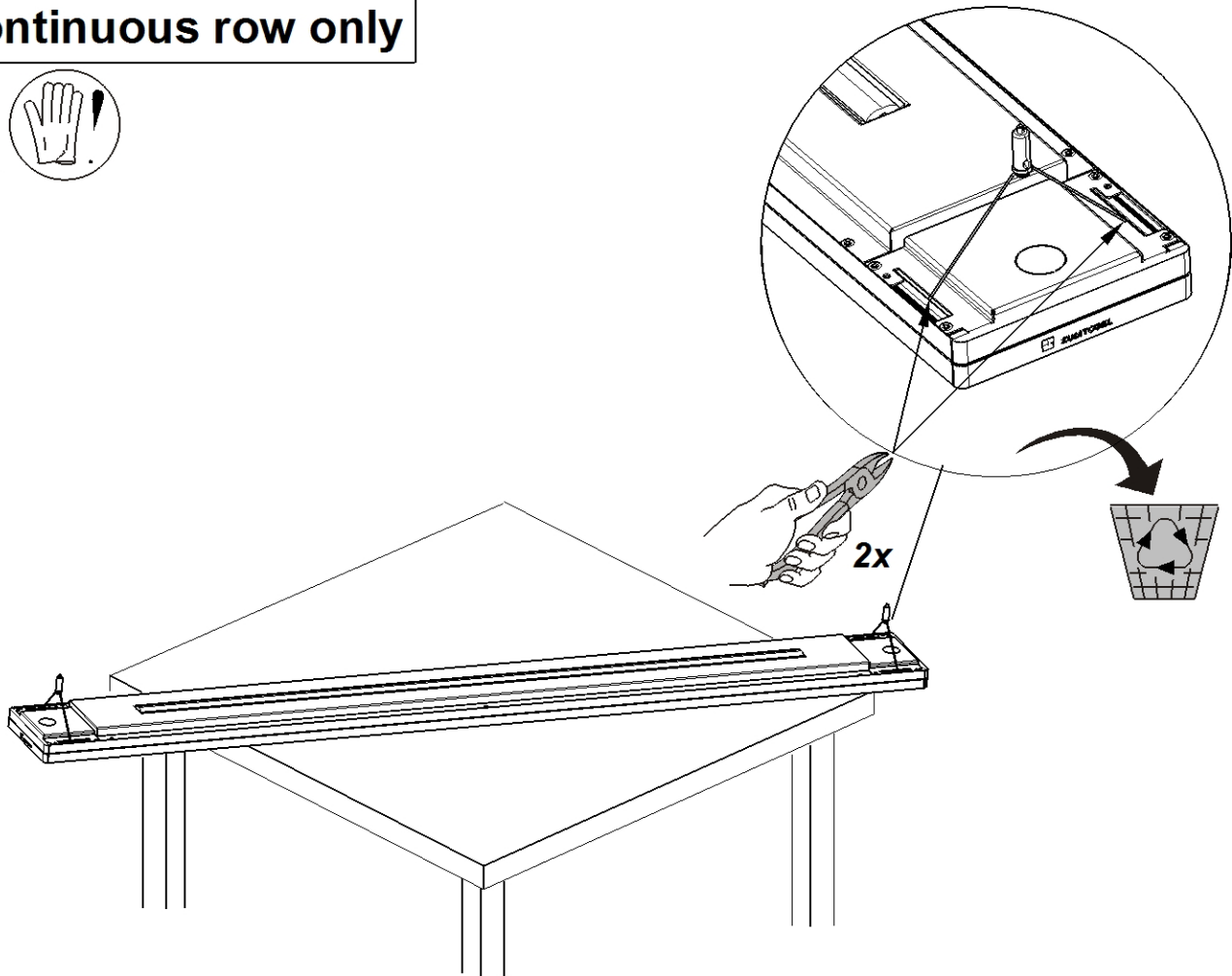

B4 continuous row only

b

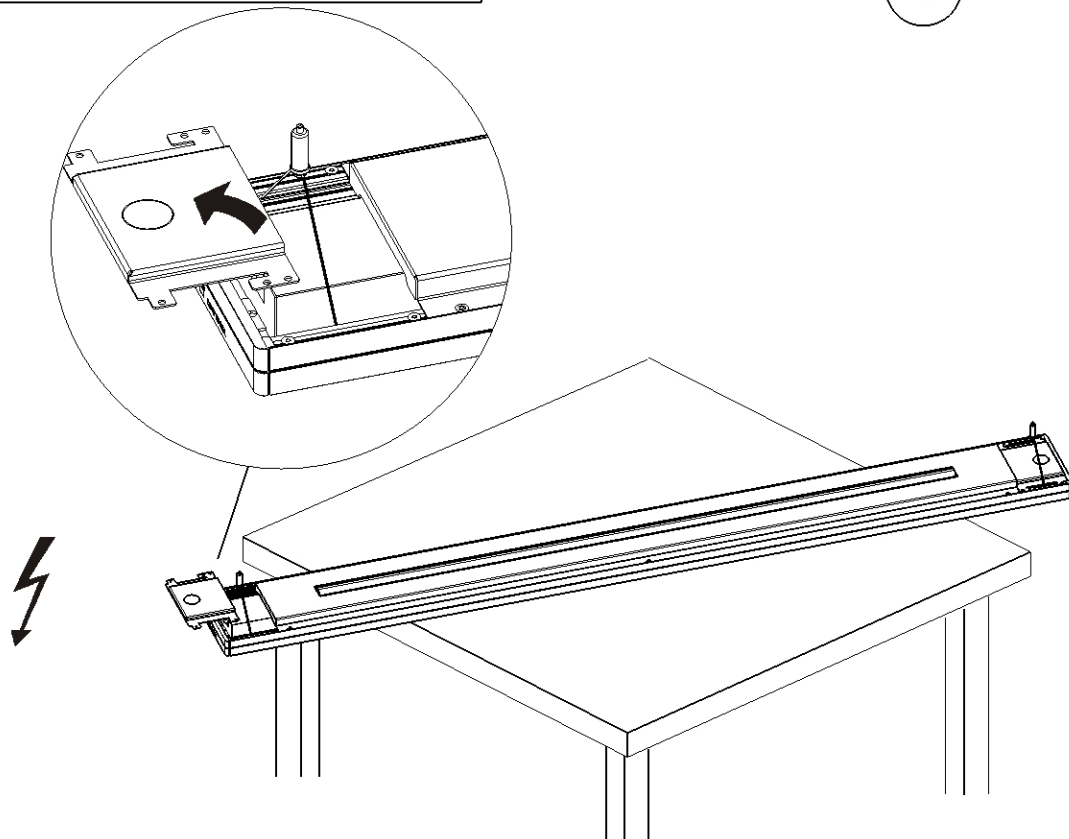

B7 continuous row only

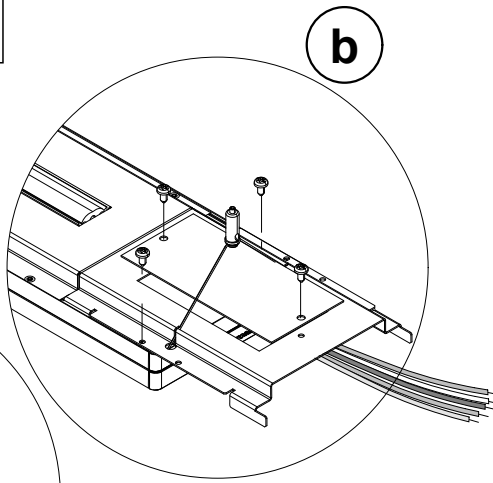
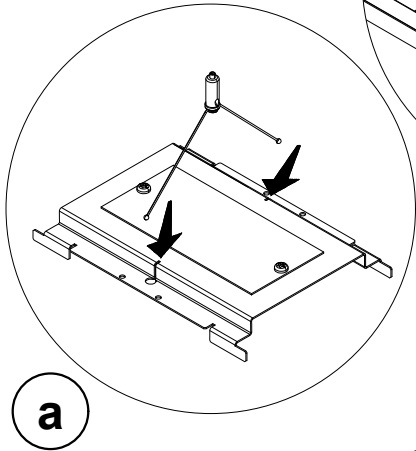
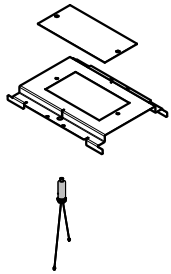

TX10
0,6 Nm

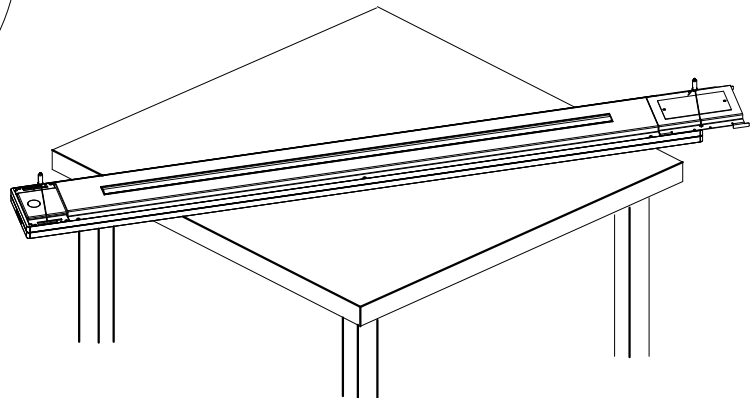
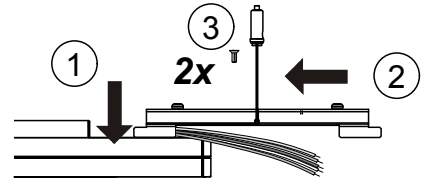

B8 continuous row only

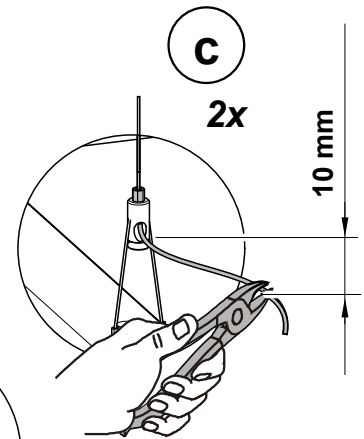
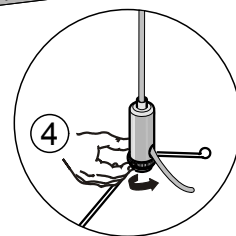
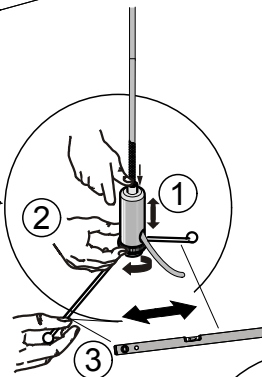
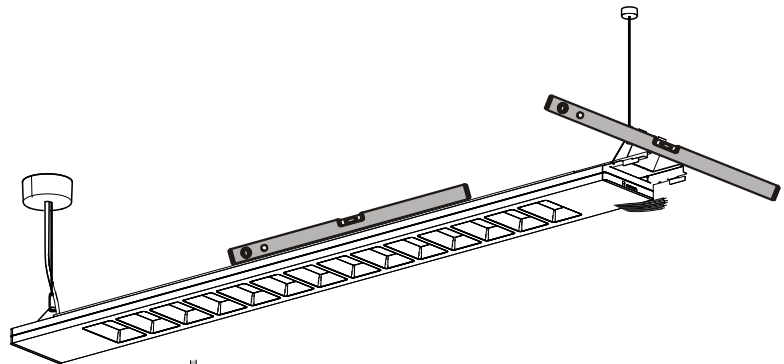
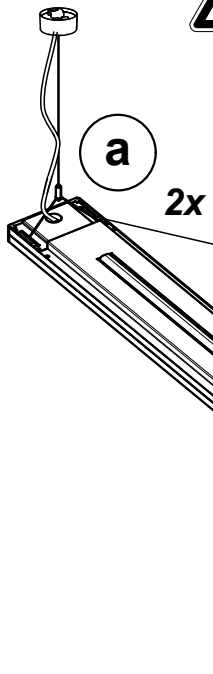

B11 continuous row only

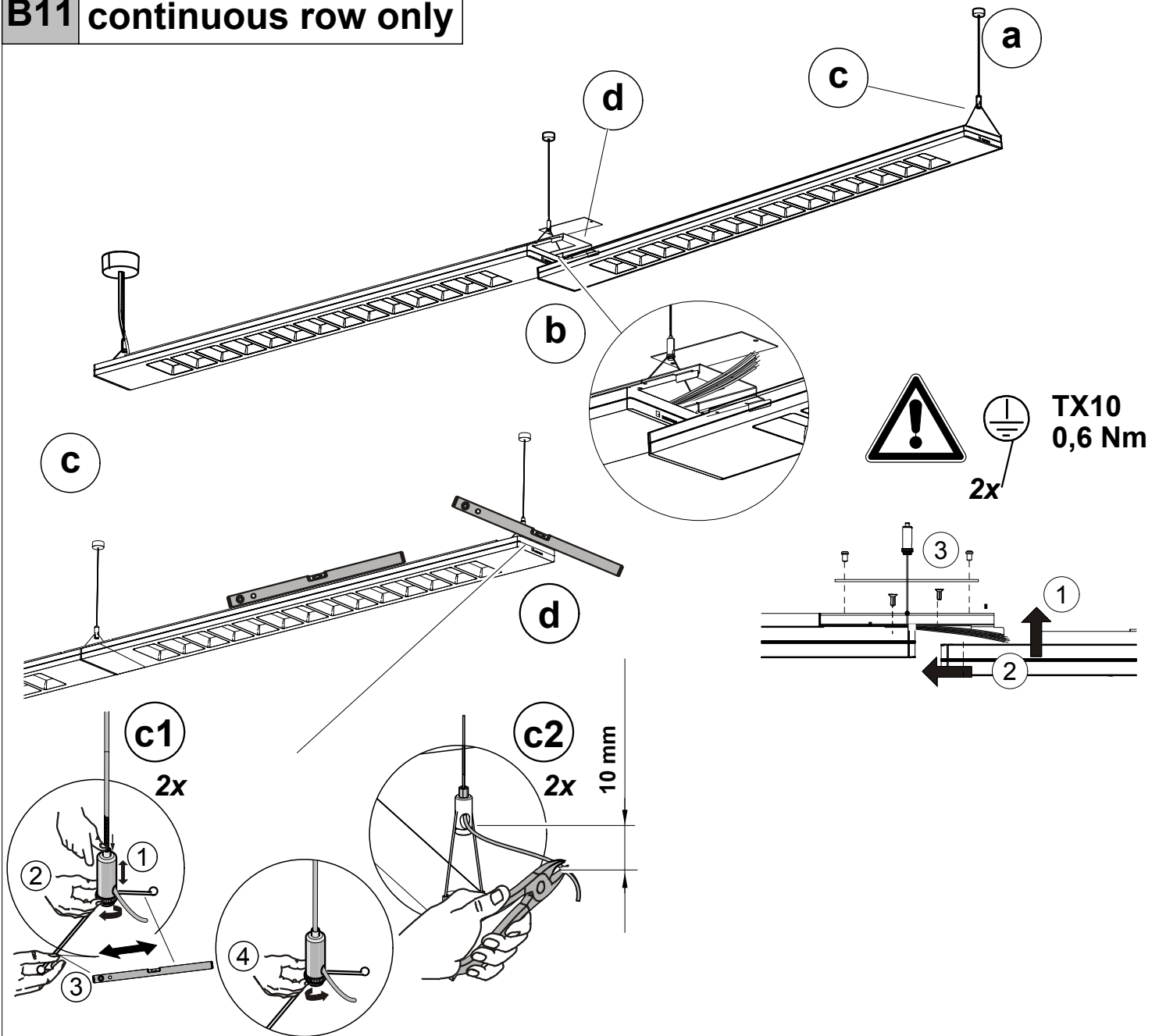

B12 continuous row only

